

ATHENS ROUND PENDANT



CONSTRUCTION:

- Fabric shade
- White acrylic bottom diffuser with decorative crystal finial
- Crystal stem accents
- 36 in. standard stem kit includes 6 in., 12 in. and 18 in. sections for adjustability
- Additional stem sections available, maximum height 12 ft.
- 12 ft. of field adjustable wire included

ELECTRICAL:

- 120V medium base sockets
- Integrated LED option (50,000 Hrs., 90 CRI, CCT 3000K)

CERTIFICATION:

- cULus Listed (medium base)
- ETL Listed (LED)

ATHENS ROUND PENDANT

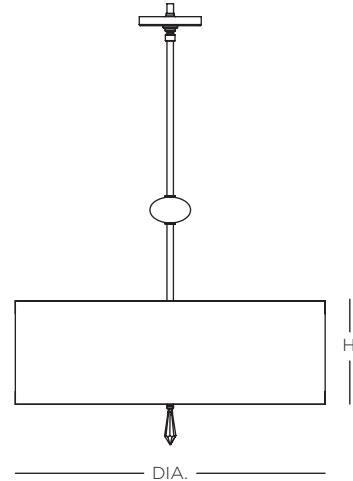
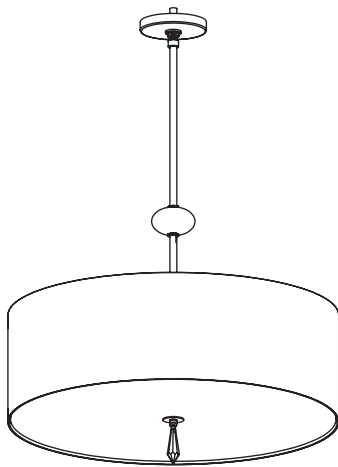

Specifications			Medium Base	Integrated LED	
Size	DIA.	H	Sockets	Source Lumens	Wattage
01	16"	8"	2 x 75W max	2400	30W
02	24"	12"	3 x 75W max	3200	44W
03	32"	16"	3 x 100W max	4400	55W

Ordering

Model	Size	Lamping	- Finish	- Fabric
SATHP	01 = 16"	MB Medium Base Socket	BN Brushed Nickel	203 Black Silk Dupioni
	02 = 24"	L1 LED (120V TRIAC Dimming)	PN Polished Nickel	206 Ivory Silk Dupioni
	03 = 32"	L2 LED (120-277V 0-10V Dimming)		209 White Silk Dupioni

Example: SATHP01L2-PN-206

Finish Options



BN
Brushed Nickel

PN
Polished Nickel

Fabric Options



203
Black Silk
Dupioni

206
Ivory Silk
Dupioni

209
White Silk
Dupioni

All specifications and dimensions subject to change without notice.