

UPTOWN BALL PENDANT



Hand-Rubbed Bronze

CONSTRUCTION:

- Intersecting tubular rings with multiple sockets
- Comes standard with second canopy and 6 ft. chain
- 12 ft. of field adjustable wire included
- Recommended for use with vintage Edison bulb

ELECTRICAL:

- 120V medium base sockets

CERTIFICATION:

- cULus Listed

UPTOWN BALL PENDANT

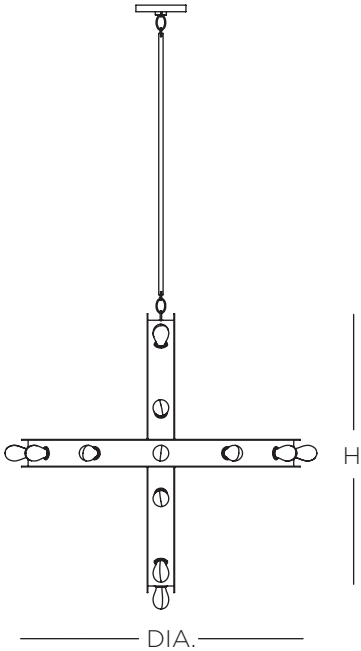

Specifications			Medium Base
Size	DIA.	H	Sockets
04	32"	32"	22 x 40W Max
05	36"	36"	28 x 40w Max
06	48"	48"	36 x 40 w Max

Ordering

Model	Size	Lamping	- Finish
SUTNP	04 = 32" 05 = 36" 06 = 48"	MB Medium Base Socket	RB Hand-Rubbed Bronze GD Gold Powder Coat MW Matte White Powder Coat MB Matte Black Powder Coat CU Copper Powder Coat SM Silver Smoke Powder Coat MS Warm Metallic Silver Powder Coat

Example: SUTNP05MB-RB

Finish Options

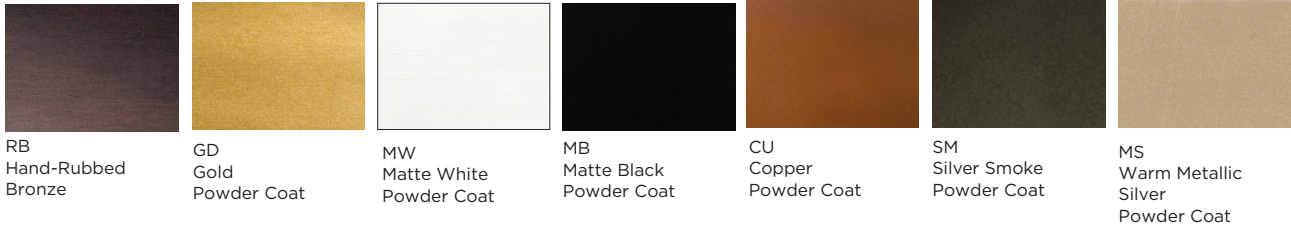

All specifications and dimensions subject to change without notice.

