

# ASTORIA ROUND PENDANT

---



Hand-Rubbed Bronze  
White Linen

## CONSTRUCTION:

- Fabric shade
- White acrylic bottom diffuser with finial
- Decorative cut metal rings accents
- 36 in. standard stem kit includes 6 in., 12 in. and 18 in. sections for adjustability
- Additional stem sections available, maximum height 12 ft.
- 12 ft. of field adjustable wire included

## ELECTRICAL:

- 120V medium base sockets
- Integrated LED option (50,000 Hrs., 90 CRI, CCT 3000K)

## CERTIFICATION:

- cULus Listed (medium base)
- ETL Listed (LED)

# ASTORIA ROUND PENDANT

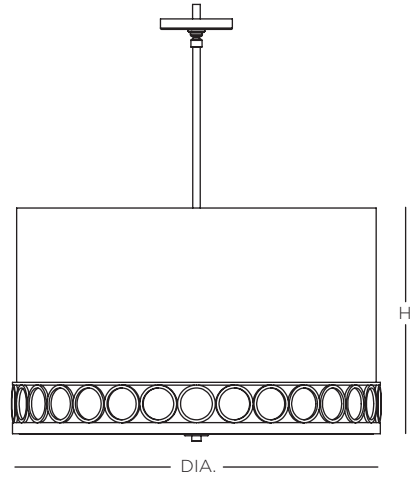
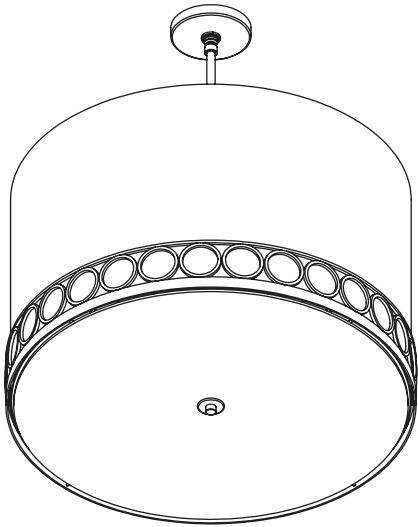

Specifications		Medium Base	Integrated LED		
Size	DIA. H	Sockets	Source Lumens	Wattage	
04	16" 10"	2 x 75W max	2400	30W	
05	24" 16"	3 x 100W max	3200	44W	
06	32" 20"	3 x 100W max	4400	55W	

## Ordering

Model	Size	Lamping	- Finish	- Fabric
SATRP	04 = 16" 05 = 24" 06 = 32"	MB Medium Base Socket L1 LED (120V TRIAC Dimming) L2 LED (120-277V 0-10V Dimming)	PN Polished Nickel RB Hand-Rubbed Bronze	301 Beige Linen 303 White Linen

Example: SATRP05L2-RB-301

## Finish Options



PN  
Polished Nickel

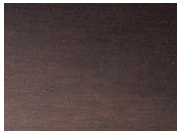

RB  
Hand-Rubbed Bronze

## Fabric Options



301  
Beige Linen



303  
White Linen

All specifications and dimensions subject to change without notice.